

## Small Portable Cartridge Collector

AER Control Systems' Small Portable Cartridge Collector (SPC-1000) is designed to be a cost effective, highly efficient, alternative approach in filtering dusts, fume, smoke, gasses, and vapors. The SPC-1000 complies with OSHA on operations generating welding fume, dusts from grinding or sanding, and other processes. Typically used for control of low to moderate concentrations of dry contaminants, the SPC-1000 is provided with a cost effective manual push button pulse-jet filter cleaning to minimize filter maintenance and reduce replacement filter costs.

The SPC-1000 has a horizontally mounted cartridge for lower center of gravity making it a safer unit. The Small Portable Cartridge Collector can be configured several different ways. The standard configuration is 115 volt, single phase, 1.5 HP TEFC electric motor, manual push button filter cleaning system, large 10 inch rear casters for excellent mobility, 5 inch front swivel casters, 6 inch by 10 foot externally supported extraction arm, and push handle with power cord and switch for plug and go operation. Optional configurations can include a HEPA Module for smoke, Carbon Module for odors, inlet options including collars, other sizes and lengths of extraction arms, no filter cleaning system for low intermittent dust concentrations, and automatic filter cleaning system for high dust concentrations.

### Options

- HEPA Module to offer 99.97% @ 0.3 micron efficiency
- Carbon Module: for the removal of gas/vapors and odors
- Multiple inlet options available
- Auto-Pulse
- No Pulse cleaning system

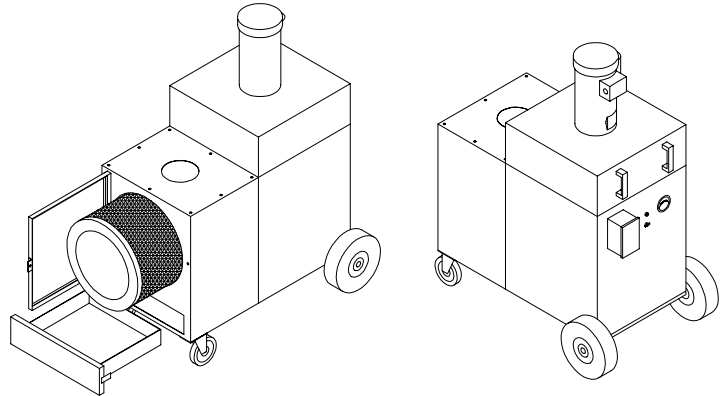

Unit	HP	CFM	Dimensions L x W x H
SPC-1000	1.5	750 CFM @ 6" W.G.	36 x 20 x 45

### Features

- 1000 Nominal CFM @ 5.5 inches of static pressure
- 115 Volt, single phase 1.5 HP TEFC motor with 8 foot cord and switch
- Direct drive backward inclined airfoil non-overloading fan
- 177 square feet of filter area providing filter efficiency of 99% at 0.5 microns
- 80/20 Polyester Blend flame retardent HEPA-like cartridge filter
- Internal baffle protecting cartridge filter
- Manual push button pulse-jet filter cleaning system
- Easy tool-less filter change-out
- Mini-helic filter change-out guage
- Dust collection drawer
- 6 inch by 10 foot externally supported extraction arm
- 10 inch rear wheels and 5 inch front swivel wheels
- 11 and 14 gauge heavy duty metal construction
- Kelly Green industrialized textured powder coat finish

## Small Portable Cartridge DownDraft Bench (SPCB-1000)

### Features

AER Control Systems' Small Portable Cartridge DownDraft Bench (SPCB-1000) is designed to provide efficient, cost effective control of dry dusts, fume, and smoke generated from sanding, polishing, buffing, grinding and other processes. Typically used for light to moderate concentrations of dry contaminants, the SPCB-1000 is the AER Control Systems' Small Portable Cartridge Collector with a downdraft table top mounted on top of the SPC-1000.

The SPCB-1000 is compact and portable, the top is an aluminum surface to protect against parts that cannot be scratched and can support a table load of 50 pounds per square feet maximum. The top has a back enclosure with hinged side wing panels. The filter in the SPCB-1000 is a 99.97% HEPA-like efficiency pleated Flame Retardant media cartridge. The cleaning system is a manual push button filter cleaning system. The SPCB-1000 has a design airflow of 1000 CFM. Downdraft table top velocity is 250 feet per minute. The SPCB-1000 is designed to be powered up as soon as you receive it by offering a power cord and switch operating at 115 volts. Optional rubber mats are available for the placing on the table top.



- Direct drive forward curved blower with a 1.5HP TEFC motor delivering 1000 CFM
- 115/220 volt single phase with power cord and plug
- Pull out dust drawer with a holding capacity of 0.9 cubic feet
- Bubble gasket seal on blower and filter access doors
- 177 square feet of filter area providing HEPA-like filter efficiency of 99% at 0.5 microns
- 80/20 Polyester Blend flame retardent HEPA-like cartridge filter
- Internal baffle protecting cartridge filter
- Manual push button pulse-jet filter cleaning system
- Easy tool-less filter change-out
- Mini-helic filter change-out guage
- 10 inch rear wheels and 5 inch front swivel wheels
- 11 and 14 guage heavy duty metal construction
- Kelly Green industrialized textured powder coat finish
- Built-in sound attenuator
- Table Top is of aluminum construction with 3/4" Holes
- Wrap Around body with swing open doors to enclose part on table
- Table top velocity is 250 FPM

### Options

- HEPA on the exhaust side of the unit
- other media available
- 208-230/460 volt motor
- Non sparking, scratch resistant rubber mat
- Different work surfaces
- 24" Fluorescent Light Kit